

THE TAYLOR CARDIGAN

#TAYLORCARDIGAN



GABRIELLE MALONE

GABRIELLE MALONE

TAYLOR CARDIGAN

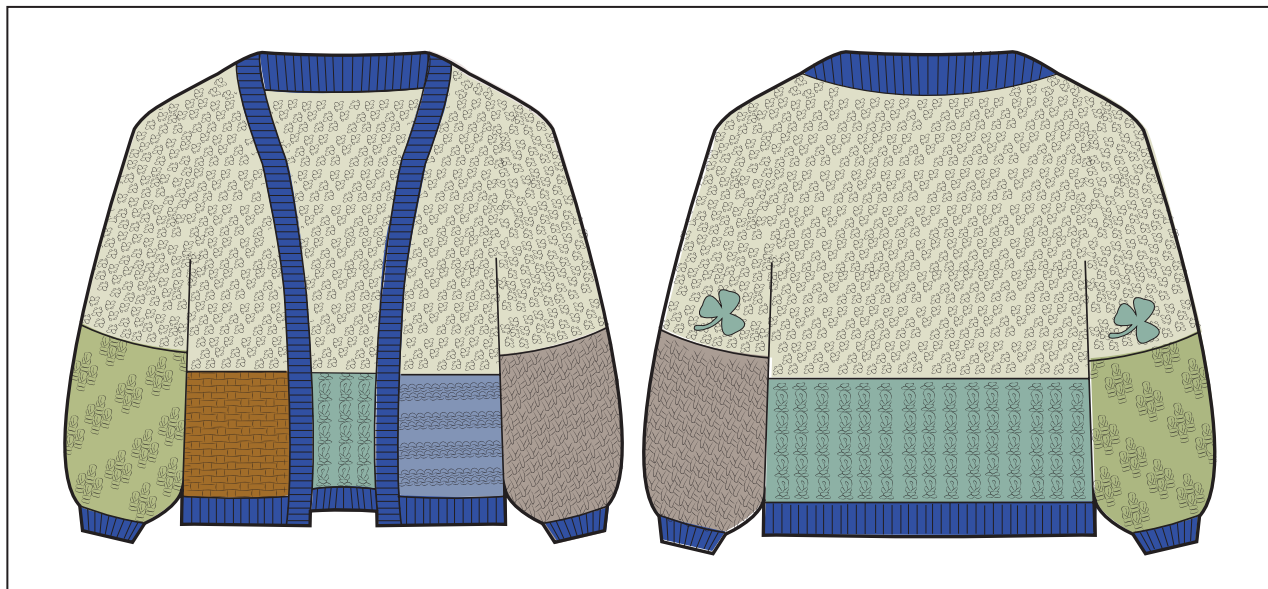

WHAT YOU WILL NEED:

- 8 mm (US 11) needles
- 7 mm (US 10.5) circular needles that are at least 80cm long
- (13 [14]) balls of 100g yarn that has approx 80m/87 yd per ball (broken done by colours on next page)
- 1 ball of 50g yarn that has approx 80m/87 yd per ball
- 2.5mm crochet hook and/or 3.5mm hook
- A darning needle to sew together (but can be done with crochet hook if you prefer).

TERMINOLOGY:

- YO = yarn over
- K. Tog = knit together, as in knit a number of stitches into one stitch together
- LLD (Left leaning decrease) = type of shaping which leans to the left
- RLD (Right leaning decrease) = shaping in which the stitches lean to the right, same as K. tog
- K = knit
- P = Purl
- * = if a piece of pattern is incased in two * it means it is repeating a number of times.
- KKPP = When starting a row, contie to knit the knit stitches and purl the purl stitches.
- K1B (Knit 1 below) = Knit below the current stitch on the needle, so you pick up both stitches.
- K w/slip (Knit with slip stitch) = Knit both the stitch on your needle and the slipped stitch next to it.
- St st = stockinette stitch
- RS = Right side of the piece
- WS = Wrong side of the piece
- CO = Cast off

SIZING:

- The pattern direction includes two sizes. S/M and M/L. When the pattern differs, information will be given for S/M first and then M/L in brackets.
- Example (size 1 [size 2])

To plan a Taylor Swift-inspired short break in Ireland go to www.Ireland.com

GABRIELLE MALONE

TAYLOR CARDIGAN

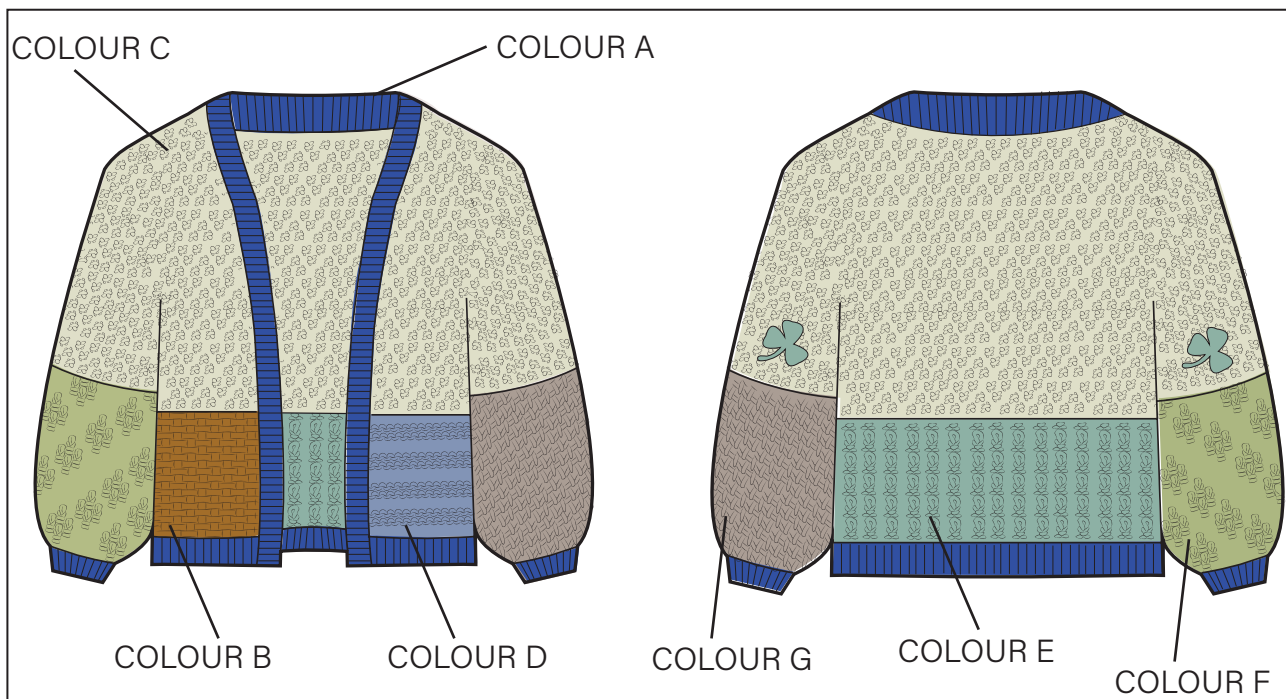

COLOUR/YARN BREAKDOWN:

- **Colour A:** (2 [3]) balls
- **Colour B:** (1 [1]) balls
- **Colour C:** (6 [6]) balls
- **Colour D:** (1 [1]) balls
- **Colour E:** (1 [1]) balls
- **Colour F:** (1 [1]) balls
- **Colour G:** (1 [1]) balls

TENSION SWATCHES:

1x1 Rib - 7mm needles

20 rows x 20 stitches
11cm wide x 12cm high

St st - 8mm needles

20 rows x 20 stitches
16cm wide x 12.5cm high

Basket Weave st - 8mm needles

20 rows x 20 stitches
14cm wide x 10cm high

Seed st - 8mm needles

20 rows x 20 stitches
17.5cm wide x 10cm high

Hurdle st - 8mm needles

20 rows x 20 stitches
15cm wide x 10.5cm high

Moss st - 8mm needles

20 rows x 20 stitches
16.5cm wide x 11cm high

Honeycomb Brioche st - 8mm needles

20 rows x 20 stitches
19.5cm wide x 8cm high

CARDIGAN SIZE BREAKDOWN:

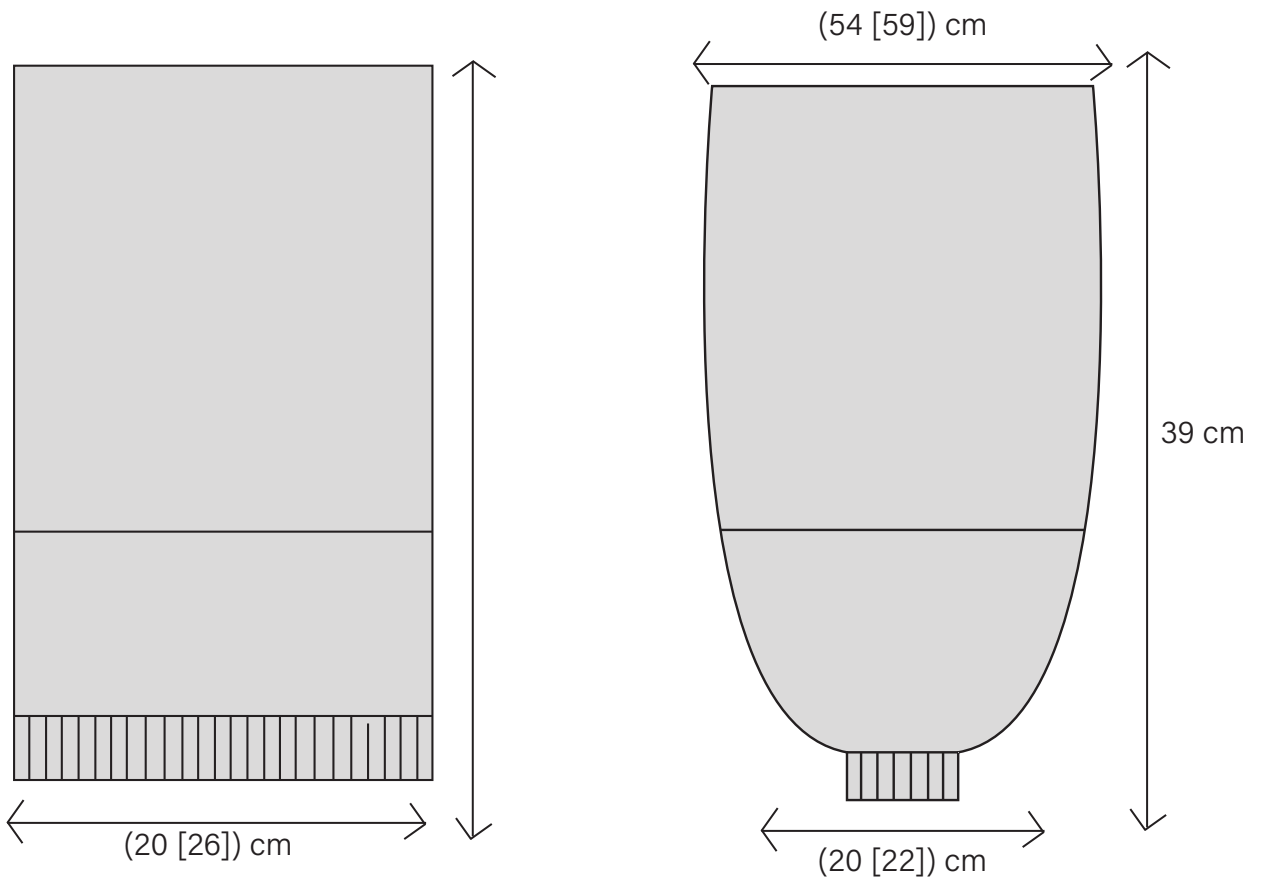
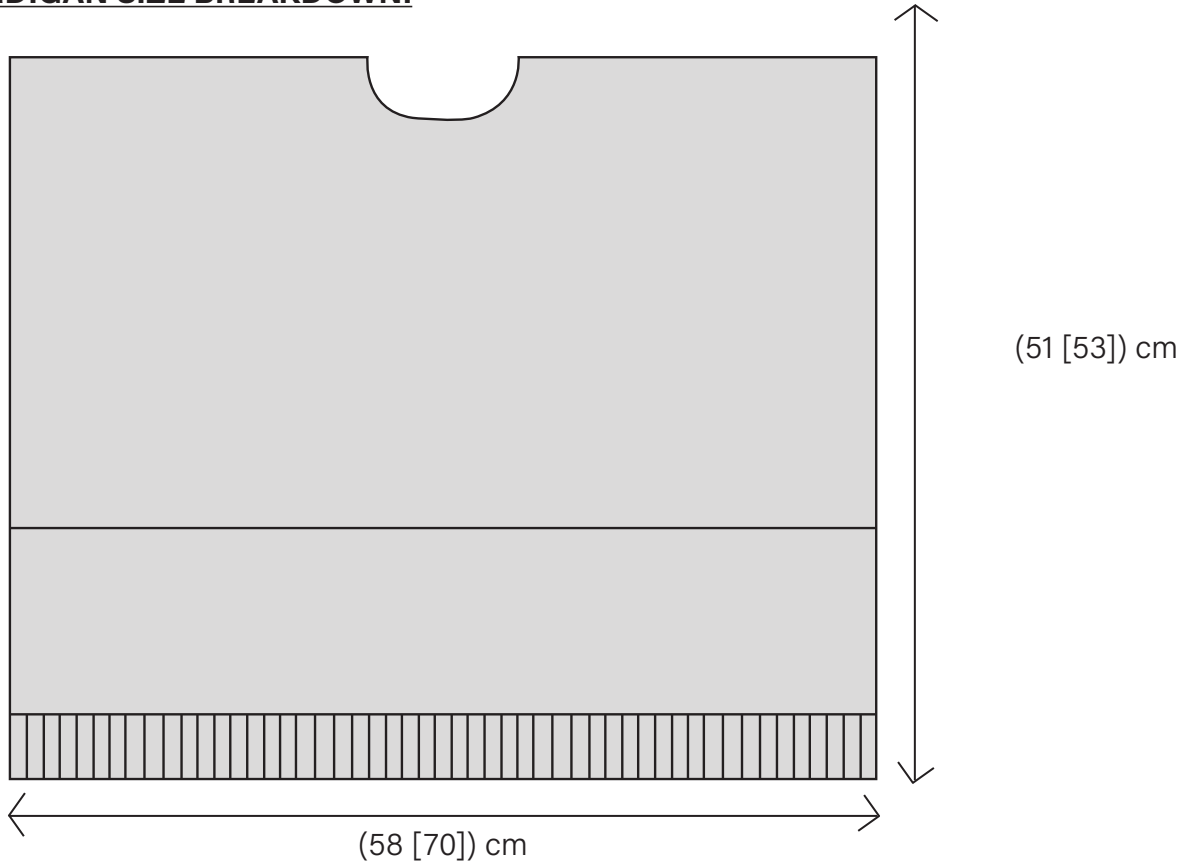

FRONT PANEL 1:

- Starting with Colour A and 7mm (US 10.5) needles, cast on (40 [52]) stitches using the long tail cast on technique.
- Knit 9 rows in the 1x1 rib stitch.

1X1 RIB STITCH:

- This stitch can be worked on rows with both an even and odd number of stitches.
- **Step 1:** *K1, P1* until end of row.
- **Step 2 (if you have an even number of stitches):** *K1, P1* until end of row.
- **Step 2 (if you have an odd number of stitches):** *P1, K1* until end of row.

- Switch to Colour B and 8mm (US 11) circular needles.
- K (0 [2]) stitches, *K (2 [1]), K2 tog*, until (0 [2]) left, K (0 [2]). (30 stitches [36 stitches])
- Next you will work in the basket weave stitch, which is a 12 step repeat pattern.

BASKET WEAVE STITCH:

- **Row 1:** Purl row on the WS.
- **Row 2:** *K1, P4, K1* until end of row.
- **Row 3:** *P1, K4, P1* until end of row.
- **Row 4:** *K1, P4, K1* until end of row.
- **Row 5:** *P1, K4, P1* until end of row.
- **Row 6:** Knit row on the RS.
- **Row 7:** Purl row on the wrong side.
- **Row 8:** *P2, K2, P2* until end of row.
- **Row 9:** *K2, P2, K2* until end of row.
- **Row 10:** *P2, K2, P2* until end of row.
- **Row 11:** *K2, P2, K2* until end of row.
- **Row 12:** Knit row on the RS

- Repeat this pattern for 29 rows.
- Change to Colour C and work a decrease row.
- **Row 30:** K2 tog (1 [00]), *K (5 [10]), K2 tog* until end of row (25 [33]) stitches.
- Next you will work the seed stitch.

SEED STITCH:

- **Step 1:** *K1, P1* until end of row
 - **Step 2 (if you have an odd number of stitches):** *K1, P1* until end of row
 - **Step 2 (if you have an even number of stitches):** *P1, K1* until end of row
 - To work the seed stitch, you are constantly knitting the purls, and purling the knit stitches.
-
- **Row 31 - (89 [91]):** Work in the seed stitch.
 - **Row (90 [92]):** Cast off on the RS.

FRONT PANEL 2:

- Starting with 7mm (US 10.5) needles, cast on (40 [52]) stitches using the long tail cast on technique.
- Knit 9 rows in the 1x1 rib stitch.
- Switch to Colour D and 8mm (US 11) circular needles.
- *K2 tog* (2 [3]), *K2, K2 tog* until (4 [6]) left, *K2 tog* (2 [3]) times. (28 stitches [36 stitches])
- Next you will work in a mix of a garter and stockinette stitch, which will be broken down below.

GARTER/STOCKINETTE STITCH:

- **Row 1 - 6:** Starting on the WS, work in stockinette stitch, starting with a purl row.
- **Row 7 - 11:** Starting on the WS, work in garter stitch, which means you knit each row no matter what side your on.
- **Row 12 - 16:** St st
- **Row 17 - 21:** Garter stitch
- **Row 22 - 26:** St st
- **Row 27 - 31:** Garter stitch

- Change to Colour C and next you will work a decrease row.
- **Row 32:** K1, *K2 tog* (2 [2]), knit until 3 left, K2 tog, K1. (25 [33]) stitches.
- **Row 33 - (91 [93]):** Work in seed stitch.
- **Row (92 [94]):** Cast off on the RS.

BACK PANEL:

- Starting with 7mm (US 10.5) needles, cast on (104 [117]) stitches using the long tail cast on technique.
- Knit 9 rows in the 1x1 rib stitch.
- Switch to Colour E and 8mm (US 11) circular needles.
- K (3 [0]), *K (1 [2]), K2 tog* until (5 {1}) left, K (5 [1]) stitches. (72 stitches [88 stitches])
- Next you will work in the hurdle stitch.

HURDLE STITCH - WHEN WORKED WITH AN EVEN NUMBER OF STITCHES:

- **Row 1:** Starting on the WS, work a purl row.
- **Row 2:** *K1P1* until end of row.
- **Row 3:** *K1P1* until end of row
- **Row 4:** Knit row on the RS
- Continue to work in the hurdle stitch pattern for 27 rows.
- Change to Colour C and you will work a decrease row.
- **Row 28:** K (3 [6]), *K (4 [5]), K2 tog* until (3 [5]) left, K (3 [5]) (61 stitches [77 stitches])

- **Row 29 - 71:** Work in seed stitch.
- Next you will work to shape the neckline.

NECKLINE SHAPING:

- **Row 72:** Starting on the RS, *K1P1* for (27 [35]) stitches, C.O. 7 stitches, *P1K1* for (27 [35]) stitches.
- You will keep your right side (when garment is placed right side up) of the work on hold, while you shape the left part of the neckline.
- **Row 73:** *K1P1* until end of row.
- **Row 74:** K1, LLD, *P1K1* until end of row. (26 [34]) stitches.
- **Row 75:** *K1P1* until end of row.
- **Row 76:** K1, LLD, *K1P1* until end. (25 [33]) stitches.
- **Row 77 - (87 [89]):** Continue to work in seed stitch
- **Row (88 [90]) :** Cast off on the right side

- Next you will pick up the (27 [35]) stitches on hold, you will flip the work so you start on the WS. To pick up stitches you continue to knit as you would do with any other row, leave a large yarn tail to seam in later and to make sure it does not accidentally unravel.
- **Row 1:** Pick up the stitches by *K1P1* until end.
- **Row 2:** Work in seed stitch until last 3 stitches, RLD, K1. (26 [34]) stitches.
- **Row 3:** *P1K1* until end
- **Row 4:** Work in seed stitch until last 3 stitches, RLD, K1. (25 [33]) stitches.
- **Row 5:** *K1P1* until end
- **Row 6 - (15 [17]):** Work in seed stitch
- **Row (16 [18]):** Cast off on the RS.

SLEEVE 1:

- Starting with 8mm (US 11) needles, cast on (68 [74]) stitches.
- Starting in a purl row, work in St st for 21 rows.
- Next you will work a decrease row.

- **Row 22:** K2, *K2 tog* 2 times, knit stitches until 6 left, *K2 tog* 2 times, K2. (64 stitches [70 stitches])
- **Row 23 - 41:** Starting with a purl row, continue to work in St st.
- **Row 42:** Switch to Colour F and work a knit row..
- Next you will work in the moss stitch.

MOSS STITCH:

- **Step 1:** *K1P1* until end of row
- **Step 2:** *KKPP* until end of row
- **Step 3 (if you have an even number of stitches):** *P1, K1* until end of row
- **Step 3 (if you have an odd number of stitches):** *K1, P1* until end of row
- **Step 4:** KKPP

- Continue to work in moss stitch until Row 64.
- Switch to Colour A and 7mm needles, next you will work a decrease row.
- **Row 64:** K3, *K2 tog* until 3 left, K3. (35 [38]) stitches.
- **Row 65 - 73:** Work in 1x1 rib stitch.
- **Row 74:** Cast off on the RS in pattern, meaning that as you cast off, you purl the purl stitches and knit the knit stitches.

SLEEVE 2:

- Starting with 8mm (US 11) needles, cast on (68 [74]) stitches.
- Starting in a purl row, work in St st for 21 rows.
- Next you will work a decrease row.
- **Row 22:** K2, *K2 tog* 2 times, knit stitches until 6 left, *K2 tog* 2 times, K2. (64 stitches [70 stitches])
- **Row 23 - 41:** Starting with a purl row, continue to work in St st.
- Switch to Colour G and you will work a decrease row.
- **Row 42:** K2, *K4, K2 tog* until 2 left, (K2 [K2tog]). (54 [58]) stitches.
- **Row 43:** Work a purl row.
- Next you will work in the honeycomb brioche stitch.

HONEYCOMB BRIOCHE STITCH:

- **Step 1:** *K1, K1B* until end of row
- **Step 2:** *K w/slip, K1* until end of row
- **Step 3:** *K1B, K1* until end of row
- **Step 4:** *K1, K w/slip* until end of row

- **Row 44 - 76:** Work in the honeycomb brioche stitch.
- **Row 77:** Work a purl row on the WS.
- Switch to Colour G and 7mm needles, next you will work a decrease row.
- **Row 78:** K2 tog (2 [1]) times, *K1, K2 tog* until 2 left, K2 tog 1 time. (35 [38]) stitches.
- **Row 79 - 87:** Work in 1x1 rib stitch.
- **Row 88:** Cast off on the RS.

SEAMING & RIBBING:

- Starting with the Back Panel, lay it out so it is RS up and place Front Panel 1 right side up, place it next to what would be your right side of the Back panel, with both shoulder seams (the cast off row) touching.
- Using a darning needle or crochet hook, sew the seams together using the horizontal invisible stitch method.
- Once that is done, repeat these steps with Front Panel 2 and the left side of the Back Panel.

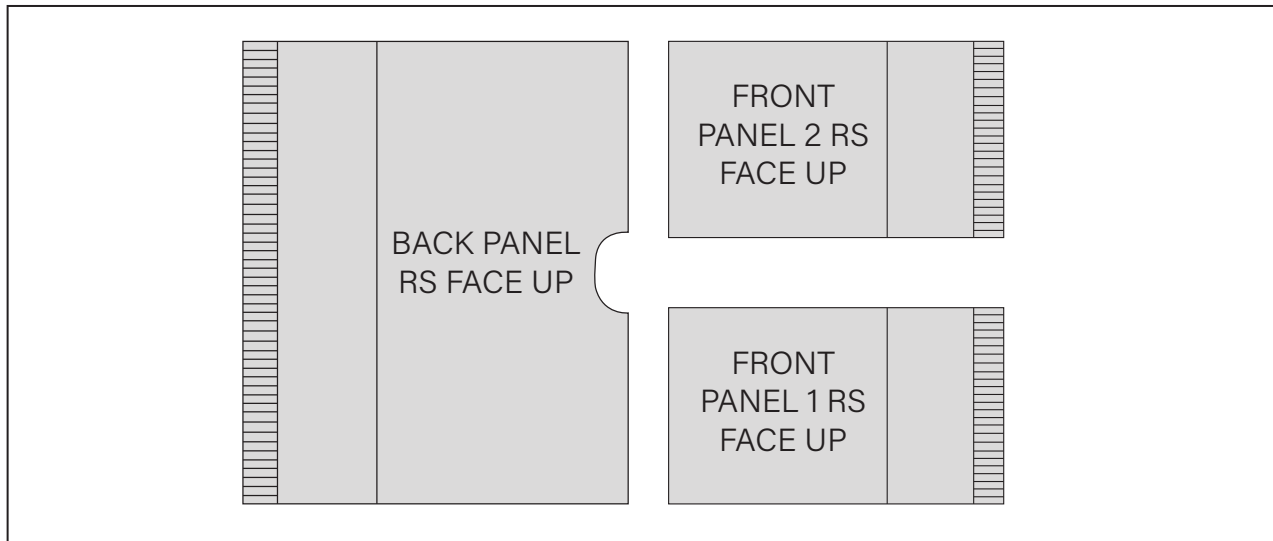

- Next you will work on the front ribbing.

RIBBING:

- Starting on the RS, pick up approximately (236 [242]) stitches, using 7mm circular needles and Colour A. Pick up the stitches from the beginning of ribbing on Front Panel 1, up the panel, around the neckline and done to the ribbing of Front Panel 2.
- **Row 1 - 7:** Starting on the WS, work in 1x1 rib stitch.
- **Row 8:** Cast off on the RS, in pattern, meaning that as you cast off, you purl the purl stitches and knit the knit stitches.

SHOULDER SEAMS:

- Starting with Sleeve 1, lay it out so it is RS up and place it so half of it is touching Front Panel 1 and the other half is layed out next to the Back Panel, also RS up (can be seen on diagram on next page).
- Using a darning needle or crochet hook, sew the seams together using the perpendicular invisible stitch method.
- Once that is done, repeat these steps with Sleeve 2 on the opposite side.

SLEEVE SEAMS:

- You can either sew the sleeves up before of after you complete the crochet shamrocks (instructions on next page).
- Starting at the ribbed sleeve cuff, and using a darning needle or crochet hook begin seaming using the vertical invisible seam.
- Continue seaming until you reach the front and back panels, where you can continue using the vertical invisible seam to sew them together..
- Once that is done, repeat these steps with the sleeves and panel on the opposite side.

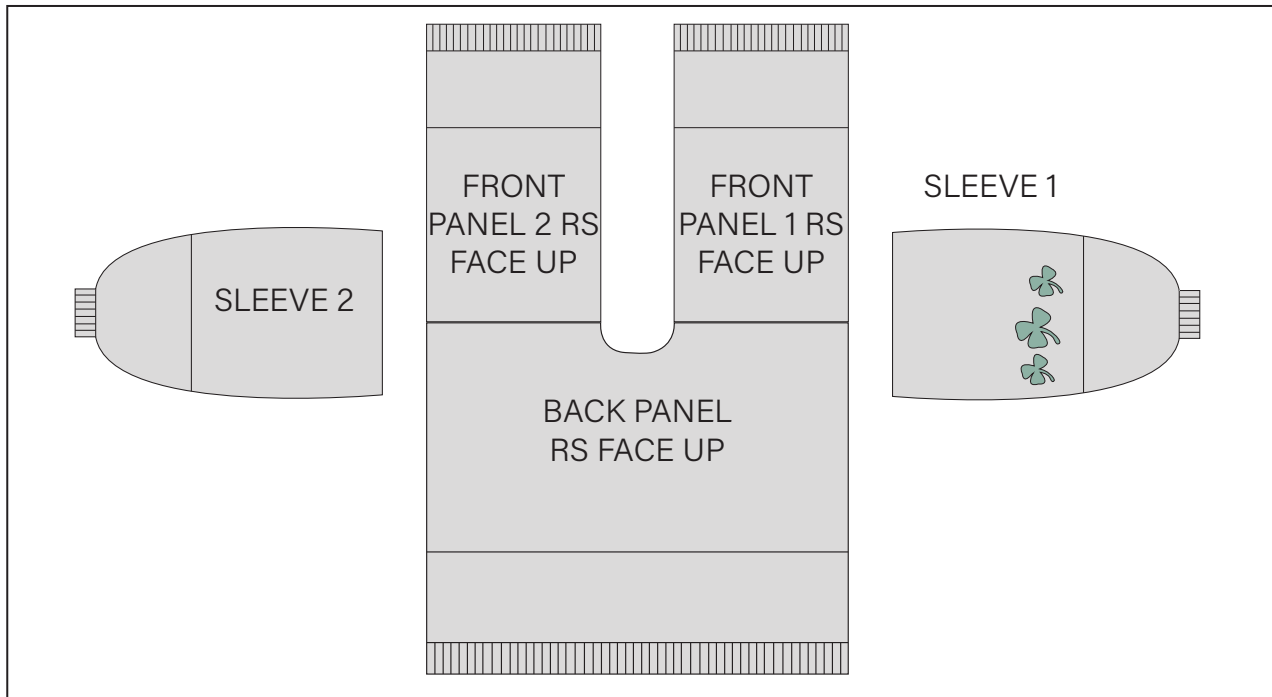

CROCHET SHAMROCK:

- Using the 1 ball of 50g yarn you have and either the 2.5mm or 3.5mm crochet hooks, you can create shamrocks to add to your cardigan.
- For the cardigan pictured in the cover photo of this pattern, the shamrocks were made with both size needles, the larger shamrock in the middle (made with 3.5mm needles) flanked by two smaller shamrocks (made with 2.5mm needles).

TERMINOLOGY:

- CH = chain stitch
- TC = triple crochet
- EXDC = extended double crochet
- DC = double crochet
- HDC = half double crochet
- C = single crochet
- SL ST = slip stitch

INSTRUCTIONS:

- To begin: Make a slip knot, ch 4 and sl st in fourth ch from hook to form a ring
- **Step 1:** Ch 10, tc in fifth ch from hook, exdc in next ch, dc in next ch, hdc in next ch, sc in next ch, sl st in last ch, sl st in ring, this will form half of your first leaf
- **Step 2:** Repeat all steps from Step 1 two more times to make half of the second and third leaves
- **Step 3:** To make the other side of each leaf, mirror the first half: sl st in last ch before ring of Leaf 1, sc in next ch, hdc in next ch, dc in next ch, exdc in next ch, tc in last ch, ch 3, sl st in same ch as tc, 1 sl st in each space of the middle line of the leaf, sl st in ring

- **Step 4:** Repeat all steps from Step 3 with the other two leaves to complete all three leaves
- **Step 5:** To make the stem: Ch 12, sl st in second ch from hook, 1 sl st in each ch across, sl st in ring
- **Finishing:** Fasten off and weave in ends
- For each elbow, make two shamrocks with a 2.5mm hook and one with a 3.5mm hook.

- Attach the shamrocks to the elbows by using the darning needle or smaller crochet hook and using the 50g yarn as thread.
- By sewing down and around the edges of the shamrock you can get a flat edge.

EASTER EGGS

- By using a darning needle and your 50g wool, you can create your own 'Easter Eggs' on your Taylor Cardigan.
- To write your own easter eggs, the best approach is by sewing in chain stitch, as this stands out more on the 1x1 rib.



**We hope you loved making and wearing your Taylor Cardigan!
Please use #TaylorCardigan and tag @GabrielleMaloneDesign
and @TourismIreland in your pictures!**